

Transformer and Ps300 board wiring

Power supply

The power supply consists of two parts. One is the transformer and the other is the Power supply PC board.

The power supply board contains a switch (relay) to connect the AC line to the transformer. The relay is controlled by Mach3 and the Out-4 connection from the breakout board. Once Mach3 is running and the user is able to click on the reset button, the AC connection will be made to the transformer. The power supply board contains the bridge rectifier, two filter capacitors and the fuses going to the output terminals. The PC board is designed for a 50 volt DC supply. The capacitors are rated for 63 volts at 10,000 micro farads each.

The transformer is a split primary and a split secondary design. The primary can be wired for 220 VAC if necessary. The secondary windings are wired in parallel.

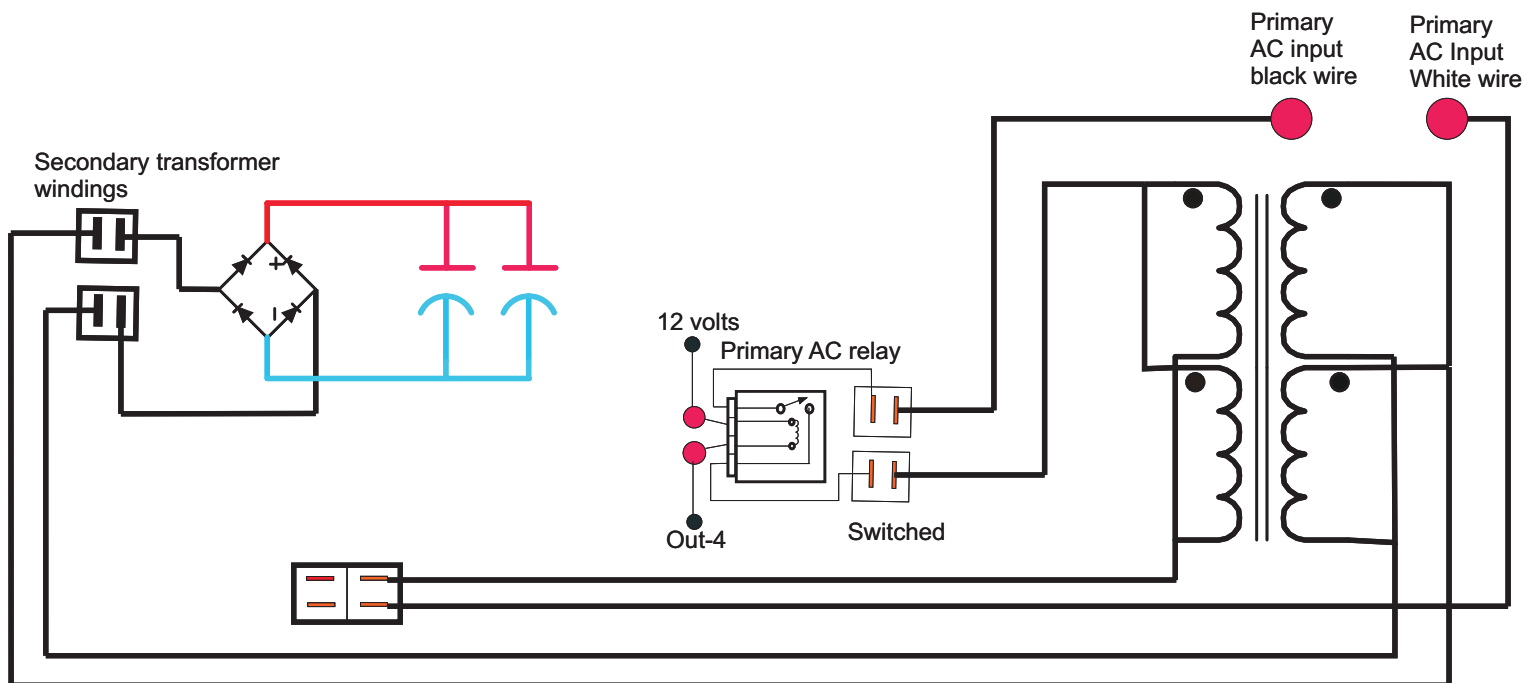

Avel Lindberg, Inc Transformers

The power supply board was designed to use either the 500 VA or the 625 VA transformer with a 35 volt secondary. This gives a DC output of about 50 VDC.

The transformer can be purchased from www.partsexpress.com

The color code for the Avel transformers is:

Primary: Blue and Gray, Violet and Brown.

Secondary: Black and Red and Orange and yellow.

If you will look closely at the label on the transformer you will see a four little dots next to the windings. The dots represent the proper phase for the windings.

On the power supply board there will be a double press-on terminal with a label (L1) next to the relay. The blue and the violet wires connect to the two terminals. Do not connect them to the terminal labeled primary. The primary terminal is for the AC line coming from the on/off switch.

The black and the orange wires will connect to the power supply board labeled TR1-3. The red and orange wires will connect to the TR1-4 terminals. You will need to extend the secondary wires to make them reach.

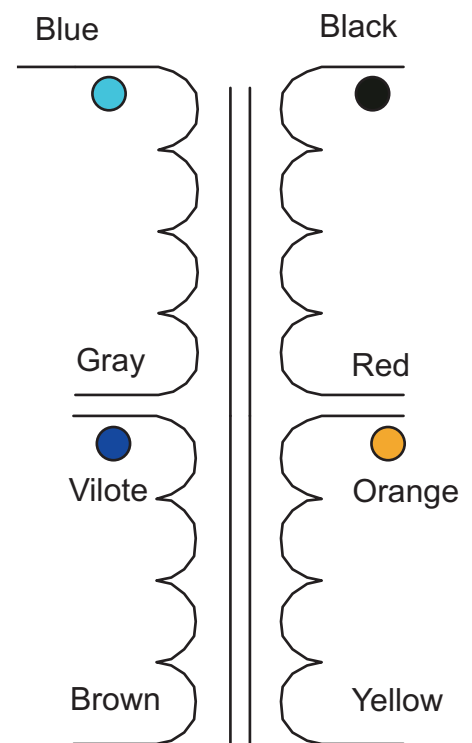

Power Supply Board Ps300

Minus DC output to the Gecko drives

DC output to the Gecko drives

Bridge Rectifier

Transformer Secondary

Transformer Secondary

Fuses

AC Line Main Input

Transformer Primary

AC main input

Transformer Primary

Relay control from Breakout Board

